

Instructions for Use

Advantix Vario connection piece

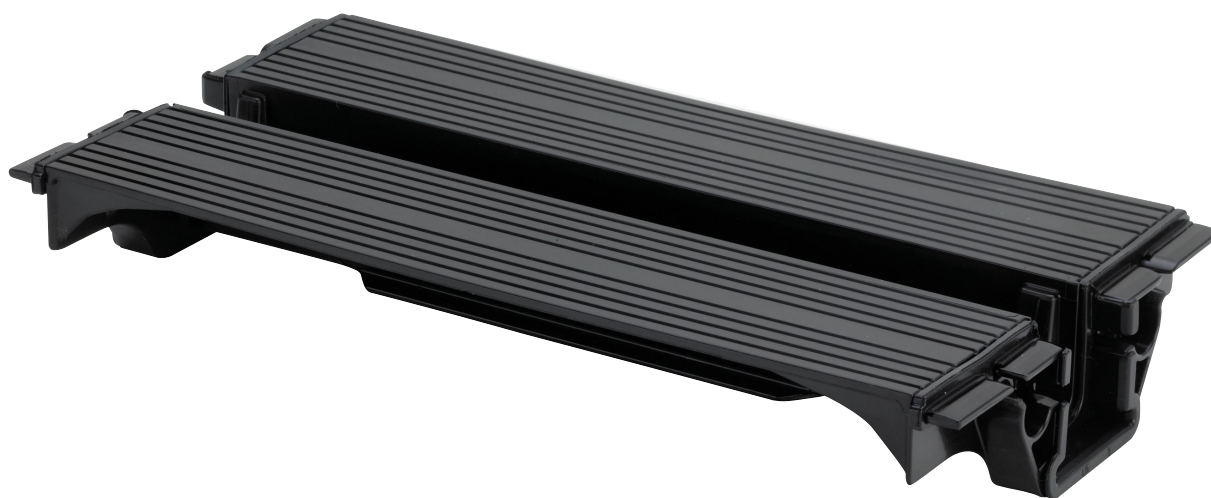

for connection of two shower channels

Model
4965.12

Year built (from)
06/2013

viega

Table of contents

1	About these instructions for use	3
	1.1 Target groups	3
	1.2 About this translated version	3
	1.3 Other applicable documents	3
2	Product information	4
	2.1 Standards and regulations	4
	2.2 Certification	5
	2.3 Product description	6
	2.3.1 Overview of the components	7
3	Handling	8
	3.1 Assembly information	8
	3.1.1 Tools and materials	8
	3.1.2 Installation dimensions	8
	3.2 Assembly	9
	3.3 Disposal	11

1 About these instructions for use

Trade mark rights exist for this document; for further information, go to viega.com/legal.

1.1 Target groups

The information in this instruction manual is directed at the following groups of people:

- Heating and sanitary professionals and trained personnel
- Tilers

Individuals without the abovementioned training or qualification are not permitted to mount, install and, if required, maintain this product. This restriction does not extend to possible operating instructions.

The installation of Viega products must take place in accordance with the general rules of engineering and the Viega instructions for use.

1.2 About this translated version

This instruction for use contains important information about the choice of product or system, assembly and commissioning as well as intended use and, if required, maintenance measures. The information about the products, their properties and application technology are based on the current standards in Europe (e.g. EN) and/or in Germany (e.g. DIN/DVGW).

Some passages in the text may refer to technical codes in Europe/Germany. These should serve as recommendations in the absence of corresponding national regulations. The relevant national laws, standards, regulations, directives and other technical provisions take priority over the German/European directives specified in this manual: The information herein is not binding for other countries and regions; as said above, they should be understood as a recommendation.

1.3 Other applicable documents

This instruction for use describes the mounting of an extension piece for an Advantix Vario shower channel in rough steps.



The instructions for use of the Advantix Vario shower channel must also be strictly observed for the mounting of the extension piece.

2 Product information

2.1 Standards and regulations

The following standards and regulations apply to Germany / Europe and are provided as a support feature.

Regulations from section: Sealing



Scope / Notice	Regulations applicable in Germany
Stress class of the underground, as well as suitable bonded sealing	ZDB-Merkblatt 8/2012
Stress class of the underground, as well as suitable bonded sealing	Leitfaden zur Abdichtung im Verbund (AIV)
Approved bonded sealings with proof of practicability in keeping with building law for stress classes A and AO	ETAG 022 T1
Approved bonded sealings with proof of practicability in keeping with building law for stress classes A, B and C	DIBt-Bauregelliste A, Teil 2 des DIBt und Prüfgrundsätze für Abdichtungen im Verbund (PG AIV-F)
Permitted bonded sealings	EN 14891
Sealing of inside rooms	DIN18534

Regulations from section: Media

Scope / Notice	Regulations applicable in Germany
Typical domestic wastewater	DIN 1986-3

2.2 Certification

Data acc. to DIN EN 1253, Table 7

Manufacturer	Viega Holding GmbH & Co.KG
Manufacturer identification mark	
Certificate of conformity	
Address	<p>Viega Technology GmbH & Co.KG Viega Platz 1 57439 Attendorn Germany</p> <p>Viega Technology GmbH & Co.KG Viega Platz 1 57439 Attendorn Germany</p>
Relevant standard	DIN EN 1253-1
Product class with respect to temperature behaviour	A

2.3 Product description

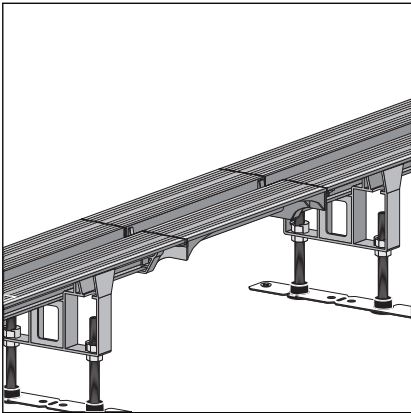

The connection piece serves the purpose of joining two base units together. In this case, one of the base unit units must be shortened by the length of the connection piece (= 210 mm).



- The connection piece may not be shortened.
- The connection piece may not be used with the L or U versions.

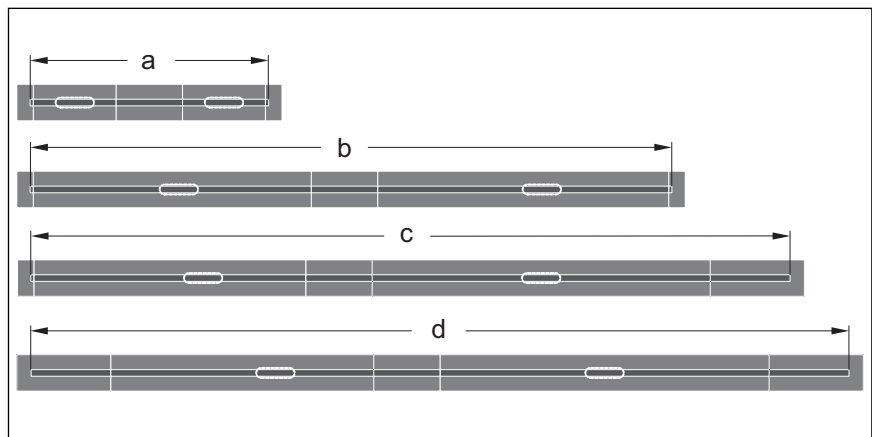

Fig. 1: Models with connection piece

- a min. 831 mm
- b max. 2422 mm
- c max. 2651 mm
- d max. 2880 mm

2.3.1 Overview of the components

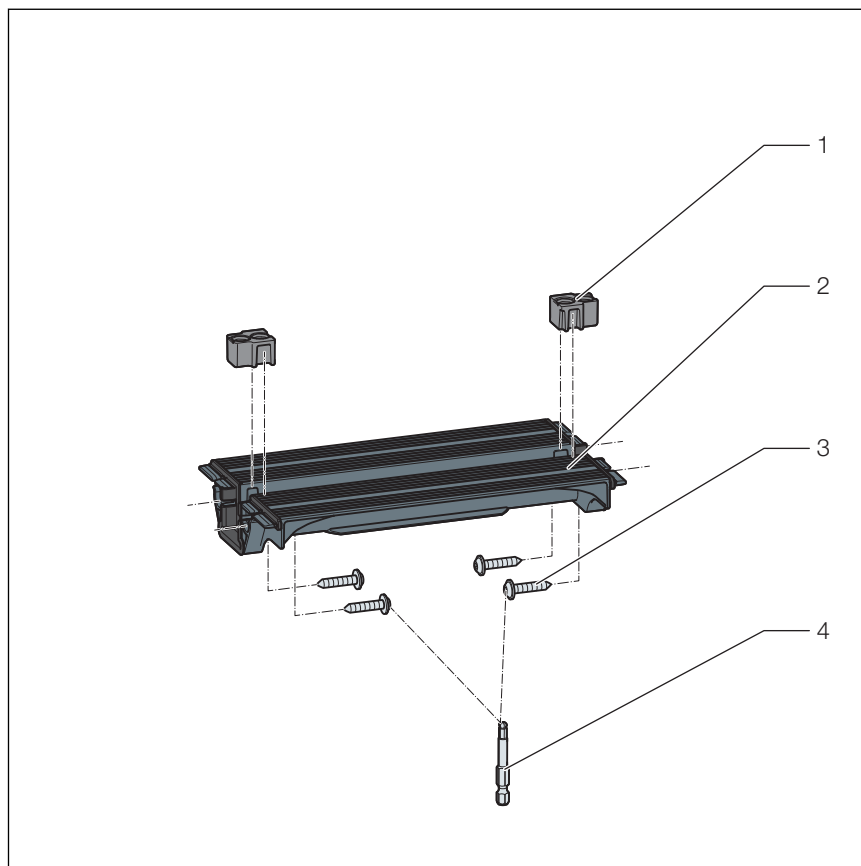

Fig. 2: connection piece, scope of delivery

- 1 spacer
- 2 Connection piece
- 3 screws
- 4 Allen key size 4

3 Handling

3.1 Assembly information

3.1.1 Tools and materials

You require

- screwdriver
- Allen key size 4

Mounting adhesive

Mounting adhesive can be used for a maximum of 18 months.

The filling date is found on the top edge of the cartridge. The first two numbers represent the month, the following number the year.

Example

085...

Filling date = August (08) 2015 (5)

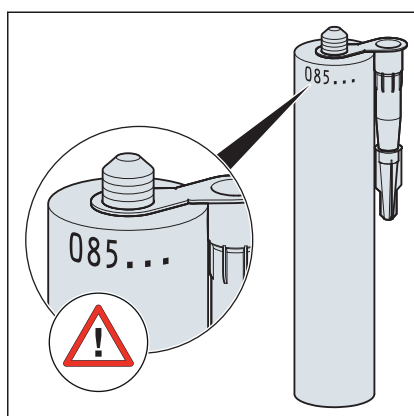

Fig. 3: Filling date of the mounting adhesive

3.1.2 Installation dimensions

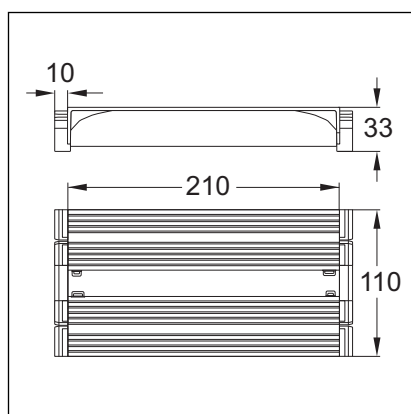

Fig. 4: Dimensions of connection piece

3.2 Assembly

Mounting the connection piece

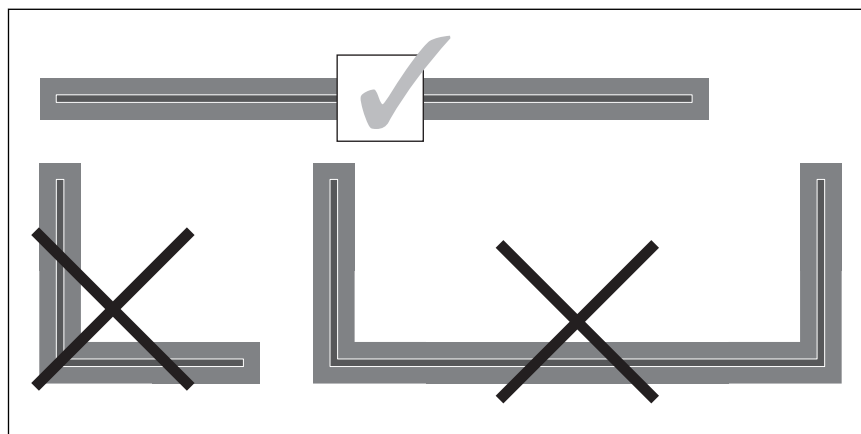
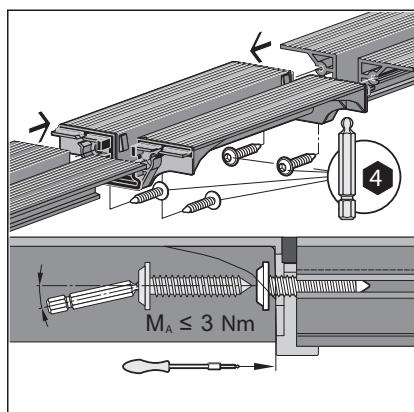

Fig. 5: Permitted installation



- Only use the connection piece in straight installation version.
- Do not shorten the connection piece!



- Screw the connection piece onto the profile straight.

When using a cordless screwdriver, make the last few turns by hand.

Only tighten screws hand-tight!



- ◇ The connection piece is properly mounted when the seal is pushed together **gently**.

Aligning the connection piece

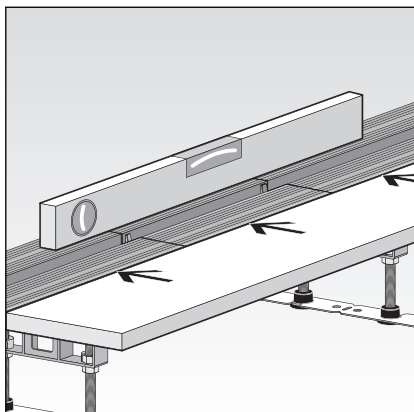

- Align the shower channel and connection piece horizontally to one another.

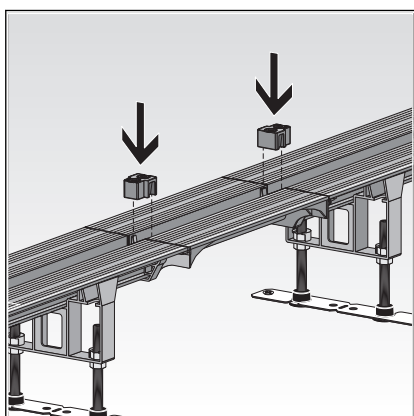

- Insert spacer.
The spacers prevent the shower channel from being deformed when the screed hardens later.

Preparing for further work

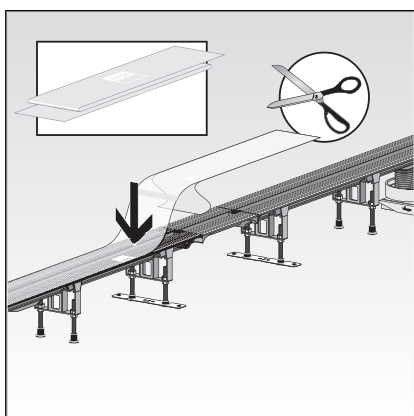

- If necessary, shorten the protective foil and stick onto the flange.
- Line shower channel with screed (also see instructions for use of the shower channel).
- Leave screed to harden.

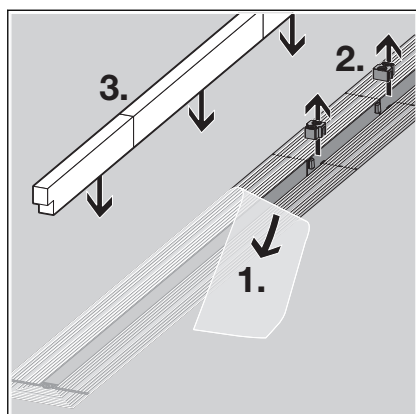

- Remove protective foil (1).
- Remove spacer (2).
- If necessary, clean the flange, e. g. with isopropanol.
- Cut protective insert to size and insert (3).
- Apply mounting and spread mounting adhesive (also see instructions for use of the shower channel).
- Apply bonded sealing (also see instructions for use of the shower channel).
- Cut the sealing tape generously.

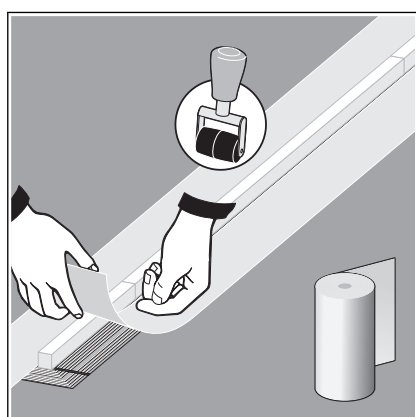

- Position the sealing tape on the flange so that the flange and screed are uniformly covered.
Overlap the corners in the process.
- Rework the sticking points with a roller.

Further processing see instructions for use of the shower channel.

3.3 Disposal

Separate the product and packaging materials (e. g. paper, metal, plastic or non-ferrous metals) and dispose of in accordance with valid national legal requirements.



Viega Technology GmbH & Co. KG

service-technik@viega.de

viega.com

INT • 2020-05 • VPN190534

